



FREE-STANDING AND UNDERGROUND MODELS



Greasly

GREASLY – a part of the modern kitchen

A typical application of a grease separator is the treatment of wastewater containing fat and grease from hotels, restaurants, cafeterias and other catering or food processing operations. GREASLY will, by the removal of fat and grease, greatly reduce incidents of blocked drains and prevent contamination of sewage treatment plants.

ENEKA offers Free-standing Greasly-A and Underground Greasly-B grease separator models. The body of the separator made of polyethylene material are durable, corrosion-proof and chemically resistant, light and easy to transport.

ENEKA UAB is a Lithuanian company with long-term experience in the manufacturing of oil/water and grease separators. The sales network of ENEKA products covers not only Lithuania and the neighbouring countries as the Baltic states or Scandinavia, but many countries in Europe, the Middle East and Asia as well.

Optimal grease separation

Incoming greasy wastewater enters the grease separator through a unique inlet module which creates the circular flow path. As water passes through the separator, grease particles, lighter than water, are driven upwards by gravity and accumulated in the collection area on the water surface. At the same time, solids and other impurities heavier than water settle to sludge trap at the bottom of the tank. Treated water is discharged through the outlet pipe.



Operation principle



Selection of Nominal Size

According to European Standard EN1825-2 the nominal size shall be determined from the following formula:

$$NS = Q_s \cdot f_t \cdot f_d \cdot f_r$$

Where:

NS – the nominal size of the separator.

Q_s – the maximum flow rate in liters per second.

f_t – the temperature factor:

$f_t = 1$ if the influent water temperature is ≤ 60 °C;

$f_t = 1,3$ if > 60 °C.

f_d – the density factor:

$f_d = 1$ if density of grease/oil is $\leq 0,94$ g/cm³;

$f_d = 1,5$ if $> 0,94$ g/cm³;

(a density factor $f_d = 1$ shall be used for wastewater discharging from kitchens abattoirs, meat and fish processing plants).

f_r – the detergent and rinsing agent factor:

$f_r = 1$ detergents never used;

$f_r = 1,3$ occasionally or always used;

$f_r \geq 1,5$ hospitals and other special cases.

The maximum flow rate Q_s entering the separator shall be calculated from the equation:

$$Q_s = \frac{F \cdot M \cdot V_m}{3600 \cdot t}$$

Where:

M – the number of meals per day;

V_m – the volume of water used per meal, in liters (see table 1).

F – the peak flow coefficient (see table 1)

t – the average duration of operation a day, in hours.

Table No. 1 Volume of water used per meal V_m & Peak flow coefficient F

Type of kitchen	V_m in litres	F
Hotel	100	5
Restaurant	50	8,5
Hospital	20	15
Large catering establishment, open all-day	1,0	22
Factory/Office canteen	5	20

For nominal size selection for food processing or any other special applications please consult ENEKA engineers.



DTI Test Report

Free-standing Grease Separators **Greasly-A**

For installation inside buildings

Greasly-A is a new grease separator model made of polyethylene for free-standing installation inside buildings. **Greasly-A** is compact and lightweight but very rigid units at the same time. All separators are equipped with an integrated sludge trap. Currently, there are nominal sizes of above-ground separators available for flow rates from 2 to 20 l/s.

Easy selection of flow direction

Due to the symmetrical design of separator, the flow direction can be selected according to existing pipeline layout. Inlet or outlet pipe can be connected on the right or left side of the separator.



Convenient allocation in the room

The grease separator is maintained from one side only, therefore, it can be set up next to the wall. The accessories (inspection window, extraction pipe, disposal pump) can be attached from both sides.



Greasly-A next to the wall

Refilling unit

After disposal the separator shall be refilled by fresh water without opening of the lid and thus ensuring odour-free filling.



Disposal Pump

A special heavy-duty disposal pump (manual and automatic emptying systems of accumulated grease and solids).

Fits through any door

A tight grease separator body (width is only 700 mm of NS2 and NS4) can easily fit through any standard door. Thus Greasly-A is a good choice for installation in spaces with narrow access.



Fits through any door

Rigid and durable design

The advanced design of separator's body ensures great stiffness and perfect resistance against internal water pressure and higher temperatures.

Complete emptying of the tank

The bottom of the separator is inclined towards the center. The extraction pipe is connected at the lowest point ensuring complete emptying of accumulated grease and solids from the lowest point.

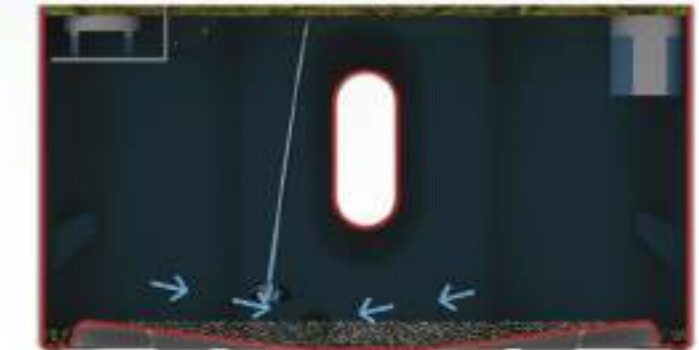

Sloped bottom

Inspection window with wiper for visual control of grease layer.

No bad odour

Access covers are tightened by a locking ring with a seal ensuring odour-free operation. There is no need to open the cover during the maintenance since accumulated grease and sludge can be disposed of through an extraction pipe or using a disposal pump.



Cover locking ring with a seal



Mixer

Mixer with 2 impellers

Before disposal, accumulated grease and sludge are blended with water to facilitate emptying of the separator.

The following main components are included in every Greasly-A model: separator tank with two airtight covers ø400 mm with seals and metallic locking rings, integrated sludge trap, sloped bottom for complete discharge, special inlet and outlet for efficient grease separation.

BASE



BASE model can be applied in areas where bad odour during maintenance will not cause any inconvenience. Access cover shall be opened for disposal of accumulated grease and solids by a vacuum truck.

Table No. 2

NS	Article No.	Weight kg	Dimensions mm		
			L	B	H
2	201-0201	78	1940	700	1190
4	201-0301	91	1940	700	1430
7	201-0401	185	1850	1850	1655
10	201-0501	207	1850	1850	1985

The data of bigger nominal sizes upon request.



MIX model is equipped with a grease alarm which is indicating when the maximum level of accumulated grease is reached. Before emptying, mixer actuated for blending grease, water and solid layers thus facilitating the disposal of the separator. The extraction pipe is provided for the emptying by the vacuum truck. After complete disposal, the separator is filled up with fresh water via the refilling unit by opening the manual ball valve.

Table No. 4

NS	Article No.	Weight kg	Dimensions mm		
			L	B	H
2	201-0203	119	1940	842	1352
4	201-0303	132	1940	842	1590
7	201-0403	233	1850	1850	1911
10	201-0503	255	1850	1850	2241

The data of bigger nominal sizes upon request.

PRIMA



PRIMA model provides odour-free operation without the need for opening of the cover. The accumulated grease layer can be observed through the inspection window. After reaching the maximum level of grease the contaminants are disposed of through the extraction pipe by a vacuum truck. After complete disposal, the separator is filled up with fresh water via the refilling unit by opening the manual ball valve.

Table No. 3

NS	Article No.	Weight kg	Dimensions mm		
			L	B	H
2	201-0202	88	1940	842	1286
4	201-0302	101	1940	842	1526
7	201-0402	198	1850	1850	1655
10	201-0502	220	1850	1850	1985

The data of bigger nominal sizes upon request.

PUMP-M



After reaching the maximum level of grease the heavy-duty disposal pump is activated. The manual 3-way valve shall be consecutively switched to positions 1 and 2:

Pos.1 - Mixing: water with grease and sludge is extracted by the disposal pump from the bottom and delivered to the top of the separator. The pump with a vortex impeller is breaking the big contaminants into smaller pieces thus facilitating the disposal.

Pos.2 - Disposal: the mixture of water and contaminants is discharged by the disposal pump into the external tank.

After complete disposal, the separator is filled up with fresh water via the refilling unit by opening the manual ball valve.

Table No. 5

NS	Article No.	Weight kg	Dimensions mm		
			L	B	H
2	201-0204	158	1940	985	1286
4	201-0304	172	1940	980	1429
7	201-0404	268	1850	2135	1911
10	201-0504	290	1850	2135	2241

The data of bigger nominal sizes upon request.

PUMP



PUMP model is equipped with an autonomous program-controlled emptying system including a disposal pump, a mixer and a grease alarm. A grease alarm is indicating when the maximum level of accumulated grease is reached. The operator activates the automatic disposal mode on the control panel or remote controller (optional). First of all, the mixer is turned on for blending grease, water and solids. Then the disposal pump is actuated for emptying of the separator. After complete disposal, the separator can be rinsed by freshwater which is filled through the refilling unit, mixed and emptied by the disposal pump. After rinsing, the separator is filled up completely with fresh water.

Table No. 6

NS	Article No.	Weight kg	Dimensions mm		
			L	B	H
2	201-0205	198	1940	1060	1352
4	201-0305	212	1940	1060	1592
7	201-0405	298	1850	2135	1911
10	201-0505	320	1850	2135	2241

The data of bigger nominal sizes upon request.

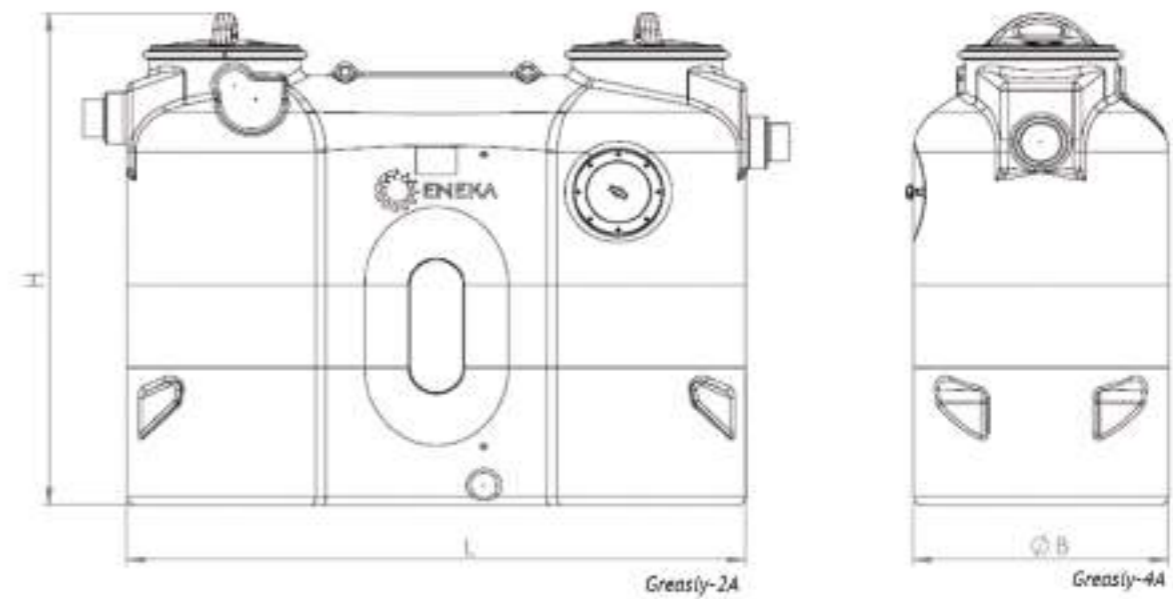

Accessories

	Grease Alarm	Extraction Pipe	Refilling Unit	Mixer	Inspection Window	Control Panel	Disposal Pump	Manual 3-way Valve
			Manual Automatic			Manual Automatic		
BASE								
PRIMA		✓	✓		✓			
MIX	✓	✓	✓	✓	✓	✓		
PUMP-M		✓	✓		✓	✓	✓	
PUMP	✓	✓	✓	✓	✓	✓	✓	✓

Optional:

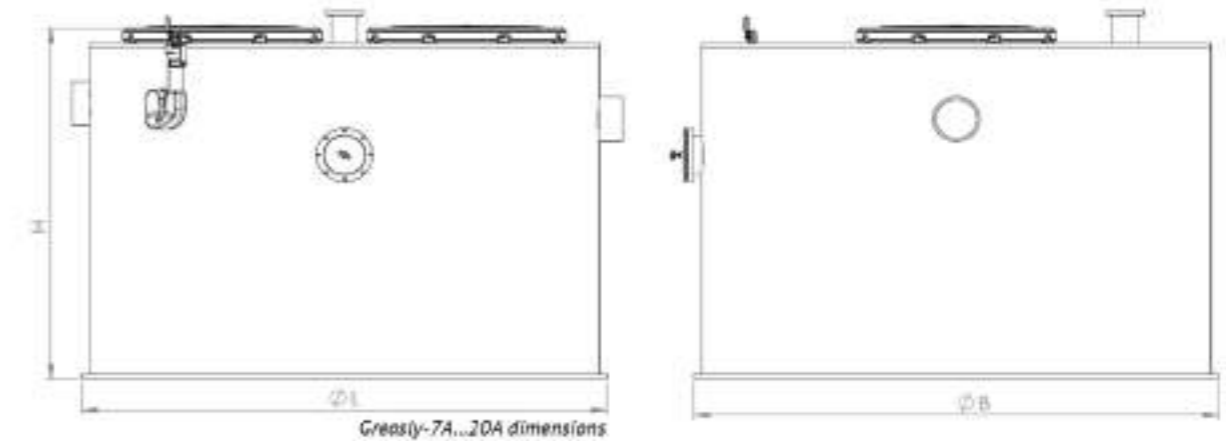

Greasly-A technical data

Table No. 7

Type	Flow rate, l/s	Sludge trap volume, l	Separator volume, l	Grease volume, l	Total volume, l
Greasly-2A	2	200	450	80	650
Greasly-4A	4	400	450	160	850
Greasly-7A	7	700	1180	280	1880
Greasly-10A	10	1000	1610	400	2610
Greasly-15A	15	1500	1798	600	3298
Greasly-20A	20	2000	2200	800	4200

Greasly-A technical data

Underground Grease Separators **Greasily-B**

Rigid body

A great stiffness of the separator body against ground and groundwater loads is achieved due to the advanced design and special ribbed structure. The consistent quality of the product is ensured by the automatic manufacturing method. Due to the seamless structure, the separator is leak and corrosion-proof.

Telescopic maintenance shaft for adjustment of the lid flush with the terrain (adjustment range 200 mm). The manhole shaft is equipped with two special seals. The first seal is located between the tank body and the manhole shaft, the second seal is between the manhole and telescope. The seals ensure that no liquid droplet will penetrate to/from the tank.



Greasily-B vertical model

Integrated ladder in the maintenance shaft provides easy and safe access to the tank.

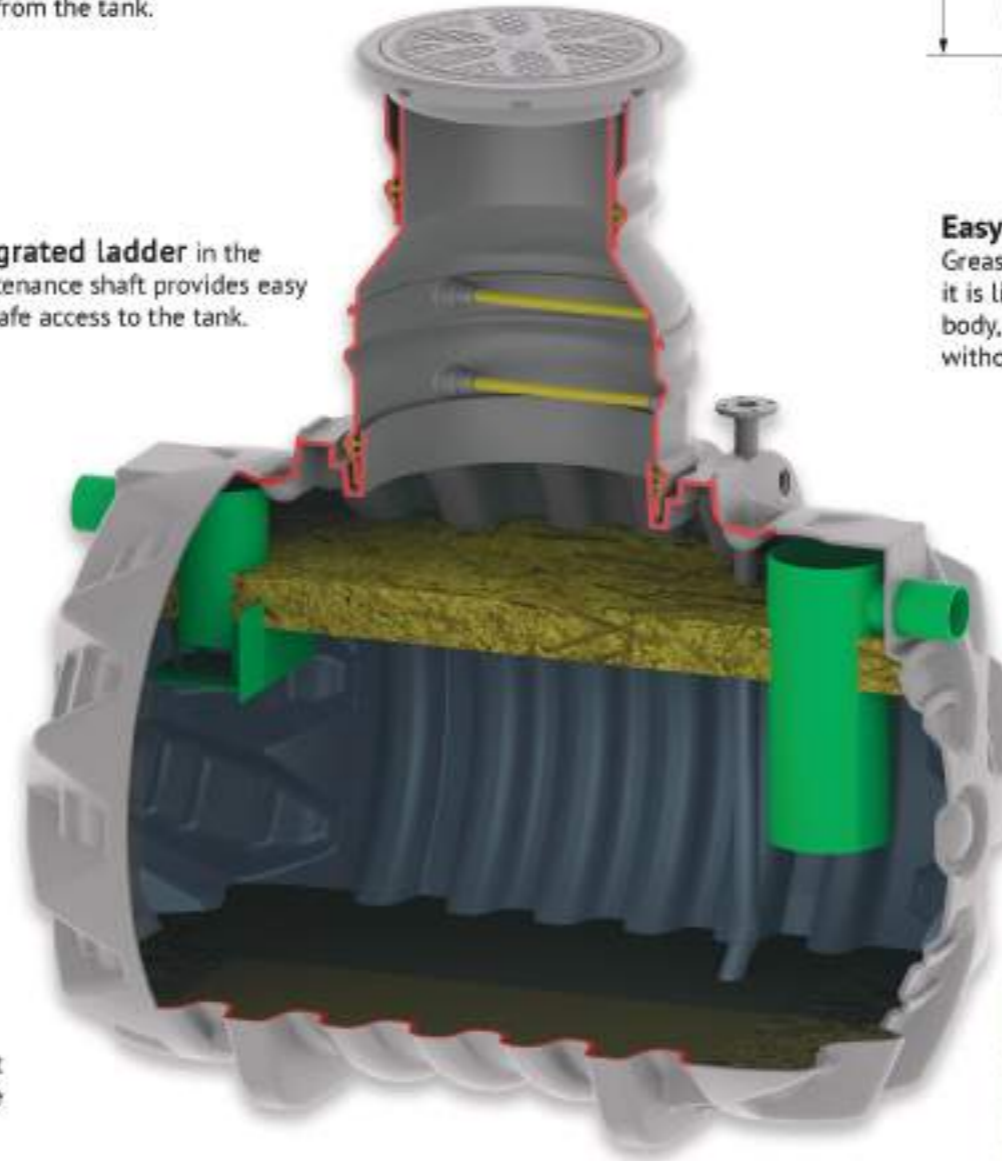

Greasily-B horizontal model

Greasily - environmental friendly product

A very important feature of polyethylene products is that they can be easily recycled and reused thus reducing the waste and environmental impact.

Simple maintenance

GREASILY requires only little service which is limited by the removal of accumulated grease and sludge by a vacuum truck. After disposal, the internal surfaces of the separator shall be cleaned by the high-pressure device. Smooth surfaces of rotomoulded polyethylene tanks are ensuring simple and efficient cleaning.

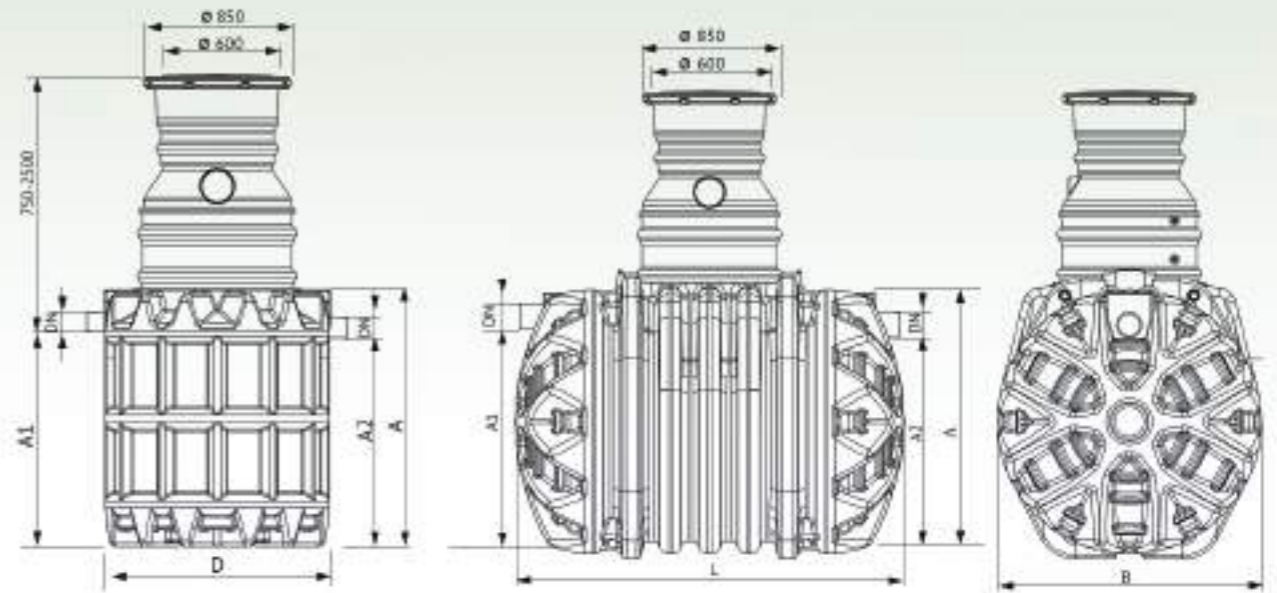

Easy transportation and installation

Greasily-B is made of polyethylene material therefore it is lightweight and easy to transport. Due to its rigid body, Greasily-B can be installed deep in the ground without any concrete reinforcements.

Extraction pipe for connection to extraction hose of a vacuum truck.



Polyethylene lid class A35 (3,5)

Lids

The maintenance shaft is designed for connection with standard polyethylene or cast iron lids for load classes from A15 to D400 according to standard EN 124. Polyethylene lid class A35 can be applied in the areas used by pedestrians, pedal cyclists and light vehicles on private household driveways (not part of the public highway).

Greasily-B technical data

Type	Flow rate NS, l/s	Sludge trap volume, l	Separator volume, l	Grease volume, l	Total volume, l	Dimensions mm					Weight kg (without shaft) S/R **	
						D/L*	A	B	A1	A2		DN
Greasily-1B	1	100	250	40	350	924	1555	924	755	685	110	85/110
Greasily-2B	2	200	550	80	750	1300	1000	1300	740	670	110	90/130
Greasily-4B	4	400	850	160	1250	1300	1490	1300	1240	1170	110	96/146
Greasily-7B	7	700	1700	280	2400	2400	1515	1410	1170	1100	160	166/255
Greasily-10B	10	1030	2730	640	3800	2500	1830	1690	1470	1400	160	206/317
Greasily-15B	15	1560	3970	750	5530	3500	1830	1690	1450	1380	200	305/415
Greasily-20B	20	2140	4930	1000	7070	4500	1830	1690	1450	1380	200	376/535
Greasily-25B	25	2500	5720	1250	8220	5000	1830	1690	1450	1380	200	475/600

* L - for horizontal and D - vertical models.

** S - Standard body for installation in depth < 1500 mm, R - Reinforced body for installation depth < 2500 mm.



Export map



**Experience
Since
1998 y.**

Manufacturing of
Oil/Water separators
Grease separators
Pumping Stations
Waste Water Treatment
Plants



Certificates

ISO 9001
ISO 14001
ISO 45001
SINTEF

SINGAPORE GREEN
BUILDING PRODUCT
"VERY GOOD"



Services

Custom Rotational
Molding
Design and
Manufacturing of
unique plastic products

UAB ENEKA
Vandžiolgos pl. 94D, LT-47467, Kaunas, Lithuania
Phone.: +370 37 377441
E-mail: info@eneka.lt
www.eneka.lt

